

# Cannizzarro reaction and reaction of benzaldehyde with ethylene glycol

(Item No.: P3101600)

## Curricular Relevance

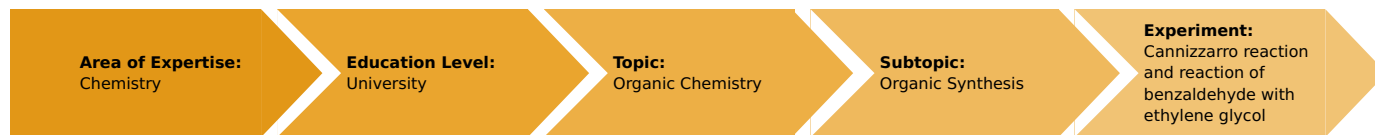

### Difficulty



Difficult

### Preparation Time



10 Minutes

### Execution Time



20 Minutes

### Recommended Group Size



2 Students

### Additional Requirements:

- Precision balance, 620 g / 0.001 g

### Experiment Variations:

### Keywords:

Cannizzarro reaction, benzaldehyde, acetals, distillation, micro distillation

## Overview

### Short description

#### Principle

In the first part of the experiment, benzaldehyde disproportionates under the effect of alkalis to alcohol-soluble benzyl alcohol and water-soluble benzoic acid that precipitates when the aqueous solution is acidified. In the second part, benzaldehyde reacts with ethylene glycol to form a cyclic acetal. This ethylene acetal is resistant against basic and oxidising reagents. In an acid medium, it once again splits up into its original products. It is because of these characteristics that cyclic acetals are used for blocking the carbonyl function in preparative, organic chemistry.

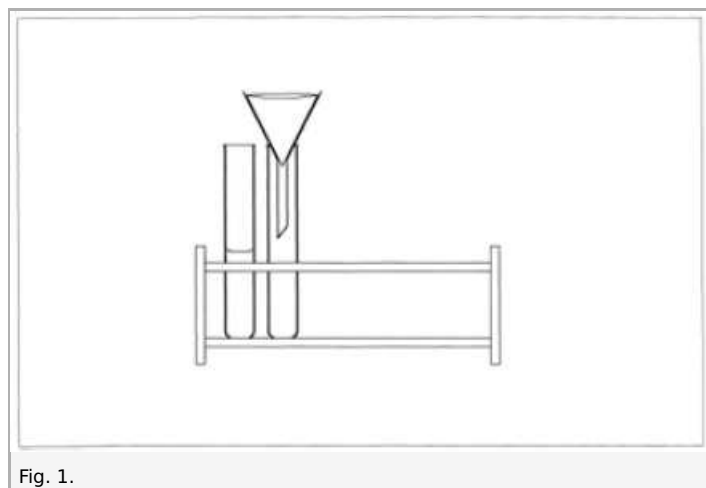

Fig. 1.

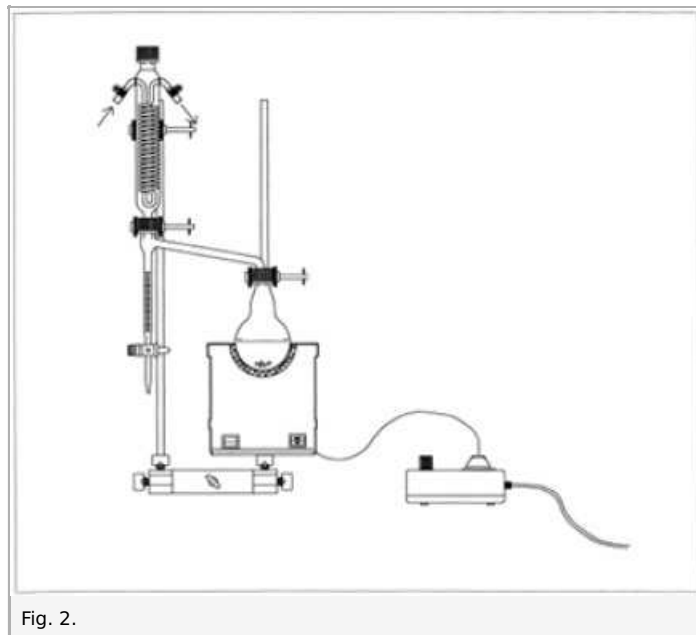

Fig. 2.

## Safety instructions



Concentrated acids are highly caustic. They burn the skin and destroy textile fabrics. For diluting, first add the water, then the acid (protective glasses, laboratory coat, gloves).

Water-free potassium hydroxide has a strong irritating effect on the skin, eyes, and mucous membranes.

Dusts and mists irritate the respiratory organs. Chemical burns lead to the destruction of the tissue and intense pain.

*First aid:* Rinse the affected skin areas and eyes with the lid gap wide open thoroughly with plenty of water.

*Disposal:* Solutions must be diluted with water, neutralised (pH 6-8), and flushed away.

Ethyl alcohol is a highly flammable liquid that can be mixed with water. In combination with air, its vapours may form explosive mixtures.

Benzaldehyde is a poorly water-soluble, low-flammable liquid with a bitter almond smell. The substance irritates the skin, eyes, and respiratory tract.

Toluene is a volatile, water-insoluble, highly flammable liquid. Its vapours are heavier than air but they can form explosive mixtures in combination with air. Toluene is harmful (low level of toxicity) and it has a strong irritating effect on the mucous membranes. A narcotic effect is possible.

*First aid:* Wash the affected skin areas with water and soap. Splashes to the eyes must be rinsed off with plenty of water with the lid gap wide open.

*If inhaled:* Fresh air.

*Disposal:* Collect flammable, halogen-free, organic solvents and solutions in a collecting vessel that is marked accordingly.

### Ethyl alcohol, absolute

H225: Highly flammable liquid and vapour.

H319: Causes serious eye irritation.

P210: Keep away from heat, hot surfaces, sparks, open flames and other ignition sources. No smoking.

## Ethylene glycol

H302: Harmful if swallowed.

H373: May cause damage to organs through prolonged or repeated exposure.

## Potassium carbonate

H315: Causes skin irritation

H319: Causes serious eye irritation.

H335: May cause respiratory irritation.

P302+352: IF ON SKIN: Wash with plenty of water/...

## Potassium hydroxide

H290: May be corrosive to metals.

H302: Harmful if swallowed.

H314: Causes severe skin burns and eye damage.

P280: Wear protective gloves/protective clothing/eye protection/face protection.

## Ortho-phosphoric acid, 85%

H290: May be corrosive to metals.

H314: Causes severe skin burns and eye damage.

P280: Wear protective gloves/protective clothing/eye protection/face protection.

## Hydrochloric acid, 37%

H290: May be corrosive to metals.

H314: Causes severe skin burns and eye damage.

H335: May cause respiratory irritation.

P234: Keep only in original container.

P260: Do not breathe dust/fumes/gas/mist/vapours/spray.

## Toluene

H225: Highly flammable liquid and vapour.

H304: May be fatal if swallowed and enters airways.

H361d: Suspected of damaging the unborn child.

P210: Keep away from heat, hot surfaces, sparks, open flames and other ignition sources. No smoking.

## Benzaldehyde

H302: Harmful if swallowed.

P262: Do not get in eyes, on skin, or on clothing.

## Equipment

Position No.	Material	Order No.	Quantity
1	Support base DEMO	02007-55	1
2	Support rod, stainless steel, l = 600 mm, d = 10 mm	02037-00	2
3	Right angle boss-head clamp	37697-00	3
4	Universal clamp	37715-00	3
5	Support ring, i.d. 70mm,	37721-01	1
6	Test tube rack, wood, for 6 tubes d= 30 mm	40569-10	1
7	Test tube,200x30 mm	36304-01	2
8	Flask,round,1-neck,250ml,GL25/13	35812-15	2
9	Water separator GL25/12	35790-15	1
10	Condenser, Dimroth type GL25/12	35815-15	1
11	Short distillation head, GL 18	35818-15	1
12	Adapter for 4 flasks, GL25	35869-15	1
13	Round bottom flask, 100ml, GL 25/12	35841-15	1
14	Round bottom flask, 50ml, GL25/12	35840-15	4
15	Lab thermometer,-10..+250C	38065-00	2
16	Secure bottle, 500 ml, 2 x Gl 18/8, 1 x 25/12	34170-01	1
17	Spring manometer, 0...-1000 mbar	34170-02	1
18	Glass tubes, right-angled, 10	36701-57	1
19	Stopcock,3-way,t-shaped, glass	36731-00	1
20	Water jet pump, plastic	02728-00	1
21	Heating mantle f. roundbottom flask, 100 ml	49541-93	1
22	Heating mantle f. roundbottom flask, 250ml	49542-93	1
23	Clamp for heating mantle	49557-01	2
24	Power regulator	32288-93	1
25	Graduated cylinder 25 ml	36627-00	1
26	Beaker, high, BORO 3.3, 150 ml	46032-00	1
27	Separatory funnel 250 ml pear-sh.	36884-00	1
28	Erlenmeyer wide neck,boro.,250ml	46152-00	1
29	Funnel, glass, top dia. 80 mm	34459-00	1
30	folded filter,qual.,185 mm,100pcs	47580-05	1
31	Abbe refractometer	35912-00	1
32	Immersion thermostat Alpha A, 230 V	08493-93	1
33	External circulation set for thermostat Alpha A	08493-02	1
34	Bath for thermostat, makrolon	08487-02	1
35	Weighing dishes, square shape, 84 x 84 x 24 mm, 25 pcs.	45019-25	1
36	Hose clip, diam. 8-16 mm, 1 pc.	40996-02	2
37	Rubber tubing, i.d. 6 mm	39282-00	6
38	Rubber tubing,vacuum,i.d.6mm	39286-00	2
39	Spoon, special steel	33398-00	1
40	Wash bottle, plastic, 500 ml	33931-00	1
41	Glass rod,boro 3.3,l=300mm, d=7mm	40485-05	1
42	Pasteur pipettes, 250 pcs	36590-00	1
43	Rubber caps, 10 pcs	39275-03	1
44	Boiling beads, 200 g	36937-20	1
45	Benzaldehyde 500 ml	30036-50	1
46	Ethyl alcohol, absolute 500 ml	30008-50	1
47	Ethylene glycol 250 ml	30085-25	1
48	Toluene 250 ml	30236-25	1
49	Ortho-phosphoric acid 85% 250 ml	30190-25	1
50	Hydrochloric acid 37 %, 1000 ml	30214-70	1
51	Potassium carbonate,98-100% 250 g	30096-25	1
52	Potassium hydroxide pellets,500 g	30103-50	1
53	Water, distilled 5 l	31246-81	1
54	Tubing connector, ID 6-10mm	47516-01	2

## Tasks

1. Show the CANNIZZARO reaction of benzaldehyde under basic conditions
2. Prepare benzaldehyde ethylene acetal from benzaldehyde with ethylene glycol

## Setup and procedure



### 1. CANNIZZARO reaction

#### Procedure

Mix approximately 5 ml of benzaldehyde with 25 ml of a 10% ethanolic potassium hydroxide solution in a test tube. Add a little alcohol, filter the solid substance out, and wash it with a little alcohol. Then, dissolve the solid substance in approximately 25 ml of water and add some hydrochloric acid.

### 2. Benzaldehyde ethylene acetal

#### Procedure

Dissolve approximately 120 ml of toluene, 10.6 g of benzaldehyde and 7.5 g of ethylene glycol in a 250 ml round bottom flask. Add 10 drops of ortho-phosphoric acid and some boiling beads to this mixture. Boil the mixture with a return flow at the water separator until no more water is separated (Fig. 3). When the solution has cooled, wash it with diluted lye and water, separate the organic phase, dry it by way of potassium carbonate and distil it.

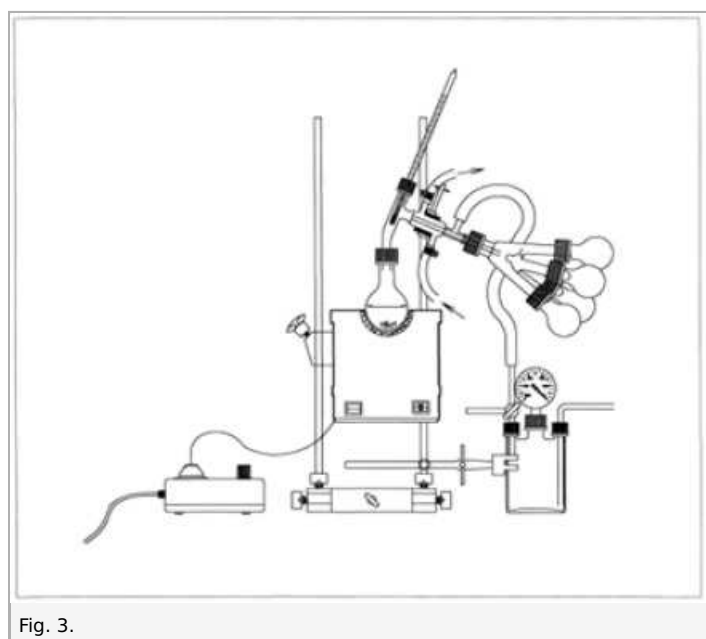

Fig. 3.

Under normal pressure, the solvent toluene distils into a 250 ml flask. Pour the remaining liquid into a 100 ml flask and equip the micro-distillation apparatus with an adapter with four flasks. Then, distil the product under the full vacuum of the vacuum pump and determine the refractive index of the purified product.

## Theory and evaluation

### 1. CANNIZZARO reaction

#### Result

The reaction mixture heats before it solidifies. During the acidification, a white substance precipitates from the aqueous solution.

#### Interpretation

Under the effect of alkalis, benzaldehyde disproportionates to alcohol-soluble benzyl alcohol and watersoluble benzoic acid that precipitates when the aqueous solution is acidified.

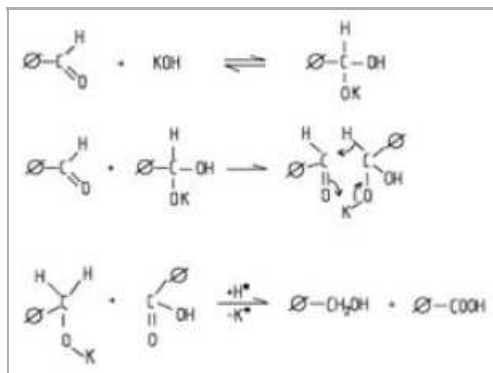

### 2. Benzaldehyde ethylene acetal

#### Result

When the solution is boiled with a return flow, approximately 2 ml of water are separated. At a pressure of approximately 20 hPa, the product starts to boil at 110-112°C.

The refractive index of the colourless liquid is  $n = 1.5267$  (literature value).

#### Interpretation

Due to the reaction with ethylene glycol, benzaldehyde forms a cyclic acetal. This ethylene acetal is resistant against basic and oxidising reagents. In an acid medium, it once again splits up into its original products. It is because of these characteristics that cyclic acetals are used for blocking the carbonyl function in preparative, organic chemistry.

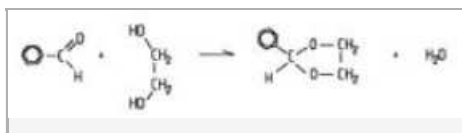

#### Data

The refractive indexes  $n$  of the compounds are as follows:

Toluol (toluene): 1.494

Benzaldehyde: 1.546

Ethylene glycol (ethane diol): 1.427

Benzaldehyde ethylene acetate: 1.5267

Molar masses:

Benzaldehyde: 106.13 g/mol

Ethylene glycol: 62.07 g/mol

Boiling point of toluene: 111 °C